

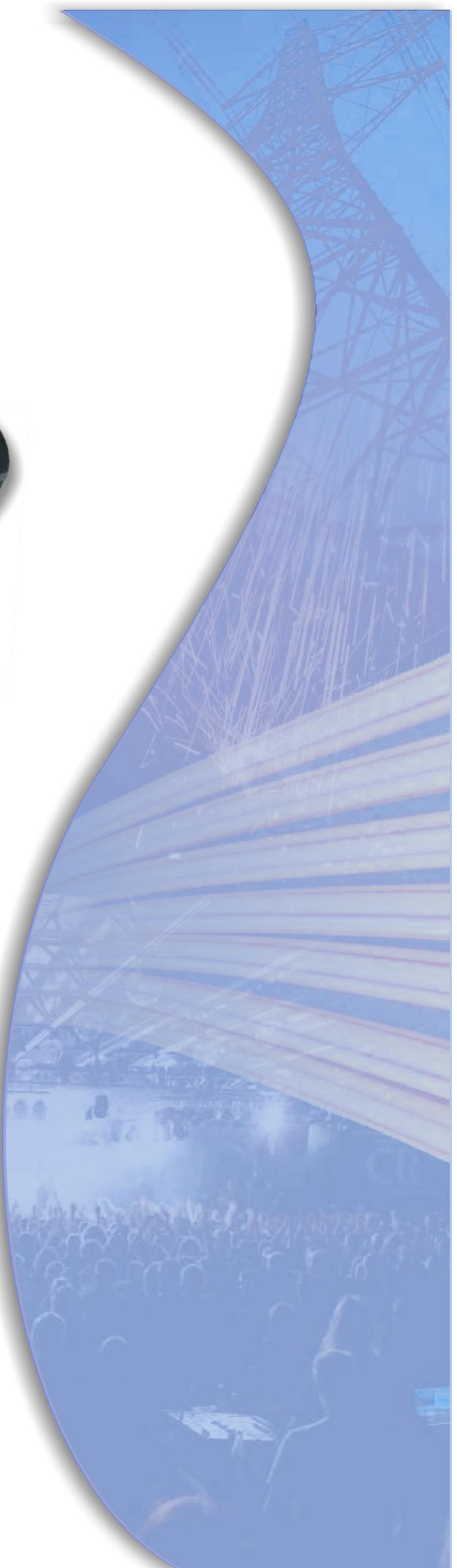

**POWERSAFE**  
500Amp & 800Amp HIGH CURRENT CONNECTORS

Raising the bar to deliver  
the ultimate in performance and safety



## Welcome To Powersafe

The Powersafe connector series is based on a standard format for mechanically keyed and locked high current single pole connectors, as utilised by the UK and European temporary power industries. This connector format was first introduced in 1993 by Litton Veam and was quickly adopted by the leading Generator Power companies, Utility companies, and the Entertainment Industry. These types of connector have now been employed in many other applications, such as Military field power, Shipboard power, Railway vehicles, Dock side power, Building installations and Switchgear.

Powersafe was designed by principal members of the original engineering team, who had developed this format of connector, and have been integrally linked with the subsequent development of these types of products over the last decade. Our extensive knowledge of electrical power connector design, the applications and customer requirements, specific to this type of connector, is probably unsurpassed by no other manufacturer in the world.

## Raising the Bar

Through listening to customer requests, and approval board comments, we have brought together the best features of the previous products, and further improved the safety and performance characteristics of the product range.

Although Powersafe connectors are still fully intermateable with the original, a redesign of the active contact element and material compositions has up-rated the current carrying capacity and the short circuit ratings of the connector to meet current customer demands. This makes Powersafe the highest current rated connector system of its type on the market.

In addition a number of other safety enhancements have been incorporated which are discussed in more detail in the following pages.



## New Features

- Increased Current Carrying Capacity
- Increased Surge Current Rating
- Increased Short Circuit Ratings
- Increased Ingress Protection Rating
- Reduced Insertion force
- Improved cable strain relief
- Improved Impact resistance
- High Temperature Resistant Materials
- Panel Mount Connector - Mounting Plates
- Rubber Hand Grip for ease of coupling and added impact protection.
- Rubber Protective Caps to protect connectors from moisture, dirt and abrasion, when uncoupled.
- RoHs Compliant



## Standard Features

- Colour Coded
- Mechanically Keyed to prevent connection errors
- Flame Retardant UL94-VO
- Locking mechanism to prevent accidental disconnection under load
- Finger Proof contacts both genders (IP2X) to prevent access to electrical contacts when uncoupled
- Screw and Crimp terminals to facilitate cables from 25mm<sup>2</sup> - 300mm<sup>2</sup> CSA
- Multipoint, self wiping contact area
- Silver Plated Contacts
- Permanent Identification marking
- High Impact bodies
- Integral cable strain relief
- Metric EN compliant cable glands, with increased cable clamping range
- No special tools required for assembly
- Daisy Chain Hook Up system
- CE Compliant



## Increased Electrical Performance

The quality of an electrical contact is dependent upon its electrical and mechanical properties.

Ragnar Holm's renowned work on the principles of electrical contact performance showed that no contact system transmits current over its entire surface, but at particular contact points.

With flat surface contacts the number of connections points is unknown, however with a multipoint system it can be assumed there will be one per bridge, and a more reliable low resistance contact path can be attained.

The higher the resistance in the electrical contact, the higher the temperature rise at the connection will be. As Power loss and temperature rise in the connector are directly proportional to the contact resistance, a low resistance current path will minimise Power loss.

For this reason most power connector designs utilise some form of multi contact connection point to attain a low resistance path.

This is an important consideration in design of Power electrical contacts, as excessive temperatures within the connector will affect other protective devices within the electrical circuit, and will lead to premature deterioration of the electrical contact. This in extreme cases could potentially lead to circuit failure.

There are for this reason many National and International specifications and regulations which detail allowable temperature rise within connectors and or specific equipments. The Powersafe connector was designed to comply with the requirements of these specifications at its full rated current.

### Current Carrying Capacity

The traditional active element of the contact design used in this type of connector, consists of multilam torsion spring band, which consists of 23 spring loaded louvers rated at 28amps each, which gives a total current carrying potential of 644amps (23 louvers x 28A = 644A) When higher currents (more than 644A) are applied to this design, the bands integrity can be compromised and excessive temperature rise results in power loss and circuit integrity issues. In addition the long term performance of the contact will be substantially reduced.

The Powersafe system uses an improved design which comprises of 29 current transfer bridges rated at 30amps each which gives a total current carrying potential of 870amps (29 bridges x 30A = 870A)

Therefore there is no contact degradation and the lower temperature rise attained at maximum rated current means, improved performance and increased safety.



## Short Circuit Current

This is a function of the connector's ability to withstand short time fault currents, without failure, thereby enabling the circuit protective devices to operate safely.

The shorter the path travelled by the current through the current bridge, the greater the short time current which can be transmitted.

Following requests from customers, specifiers and installers for product compliant to their requirements and to address potential liability and safety issues, the geometric design of the band optimises the current bridge to give an increase in short circuit ratings.

Typical short circuit rating requirements are defined within:

- 1) The UK Electricity "LV Distribution Fuse Board specification" ESI 37-2
- 2) The UK "Codes of Practice for Design and installation of temporary distribution systems delivering a.c electrical supplies for lighting, technical services and other entertainment related purposes" (BS7909)



## Powersafe Band Technology

The contact band is the active element of the design which transfers current through the connection. It consists of a series of sprung current-transfer bridges that give the following benefits.

- Low contact resistance
- Low voltage drop
- High short circuit currents
- Compact design
- Self cleaning
- Low insertion force
- High current transfer density
- High number mating cycles
- Large working range

The band is a strip-form, sprung contact element which is inserted between two conducting surfaces to transfer current. The Band consists of a series of contact bridges that provide reliable, low loss, current transfer. The contact band also has a high short-circuit rating through its compact dimensions. The band is inserted in a dovetail recess for positive location and to assure mechanical stability.

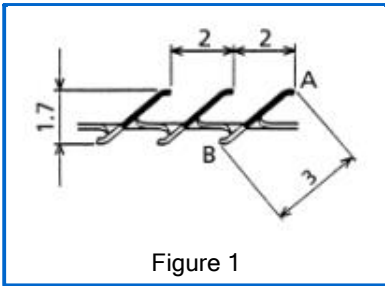

Figure 1

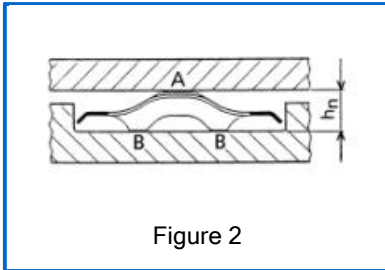

Figure 2

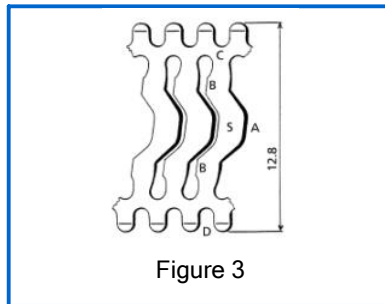

Figure 3

## Special Features

Due to its specially designed geometry and manufacture, an ideal ratio of the grid spacing to the width of the current bridges has been achieved. For a bridge length of 3mm the grid spacing is only 2mm, resulting in a high bridge density. The current bridges are therefore 50% longer than the grid spacing.

This has the following advantages:

- 1) Higher Current Carrying Capacity
- 2) Due to a larger number of current bridges per unit length, resulting from the low grid spacing of 2mm.
- 3) Large Tolerance Compensation
- 4) Due to the relatively large spring working range resulting from the 3mm length of the current bridges.

The contact force is very low in relation to the impressive current carrying capacity of the individual current bridges. This results in low insertion and withdrawal forces, a particular advantage for high current connectors.

In addition, the current bridges are arranged at an angle to the axis of insertion. This reduces wear and score marking and increases the working life of the contact.

## Design

The Band carries a large number of current bridges (S), each of which is joined to the supporting edge strips (D) through two torsion arms (C).

The current paths are defined by three contact lines to the conducting surfaces. Each bridge has one dynamic (A) and two static (B) contact lines. A single dynamic line makes electrical contact with the moving part of the contacts, while two static lines ensure contact with the locating recess.

The Band is manufactured in high grade beryllium copper alloy (CuBe2) by punching, lancing and bending. After the formed band has been hardened, it is silver plated.

The current bridge represents an independent spring which is additionally spring-loaded by the two torsion arms. Each individual bridge is thus self-sufficient in providing the contact force required for current transfer. The current bridges are connected to each other at both sides by the edge strips this also gives mechanical stability to the band. The strip edging locates the contact band securely in its recess.

## Rated Current

The current rating of the Powersafe connector is up to 800amps continuous.

A key element in determining the current carrying capacity of the connector and cable configuration is the type and cross sectional area of the cable being used. Figure 3 show typical values taken from IEE wiring Regulation BS7671 Table 4E1A reference method 12, cable in Free Air.

The values relate to single core, copper stranded cable with Rubber Insulation with an operating temperature of 90° C.

For Cables types with operating temperatures of less than 90 °C the current ratings will be reduced.

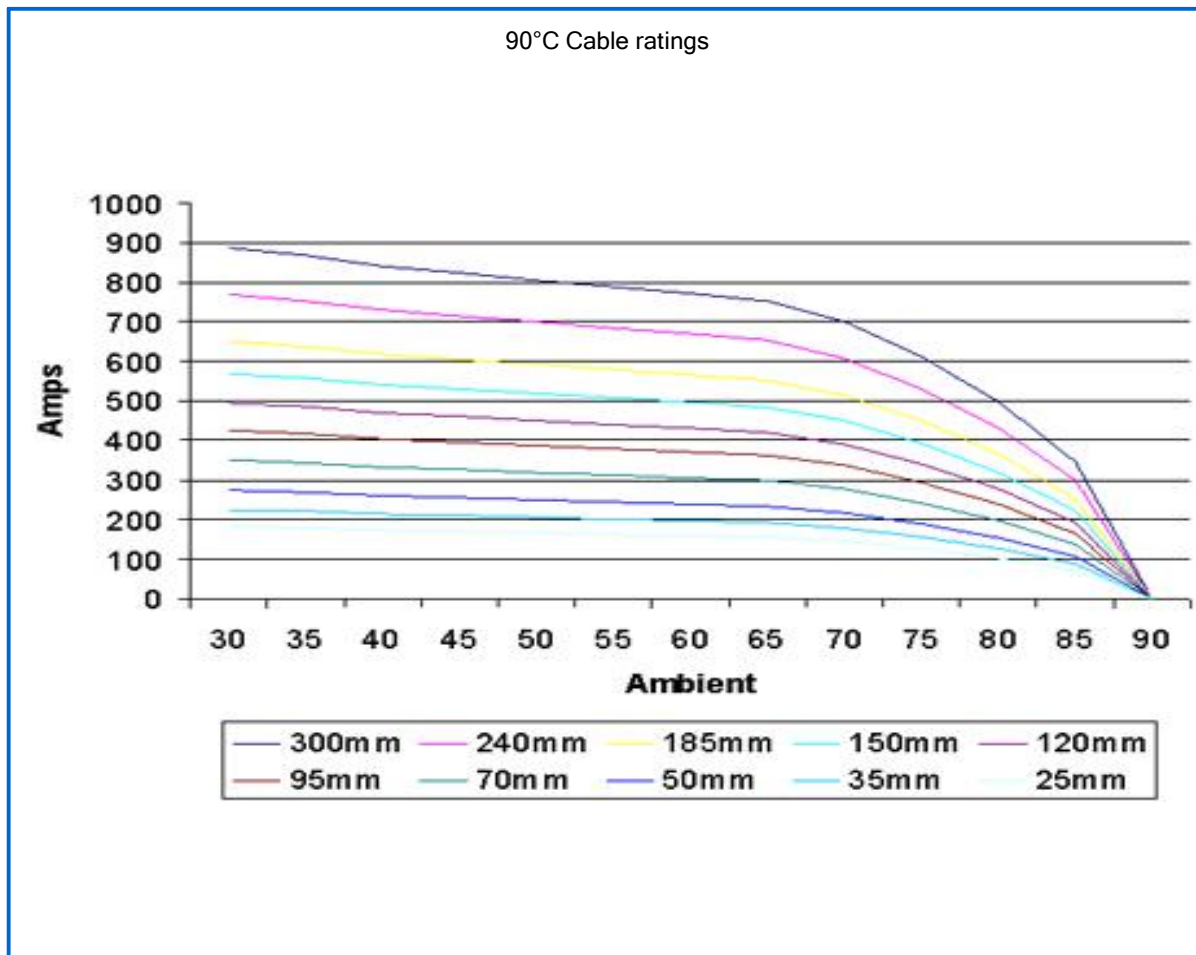

## Product Technical Overview

(a) See Ratings page 7

(b) Double Allen Screw Terminals are standard for cables up to 150mm CSA (500amp Maximum Continuous rating). Crimp terminals are standard for larger cable sections up to 300mm CSA (800amp Maximum Continuous rating).

(c) In accordance with EN 60529 when mated Powersafe meets the requirements of IP68.

In the unmated position both source and drain connectors as IP2X rated.

For full IP rating table refer to appendix 1.





### Product Technical Overview

No. of Contacts	1
(a) Maximum Continuous Current Rating	Up to 800A
Surge Current	75kA
Short Circuit Rating	Up to 35.5kA
Cable Cross Sectional Area C.S.A	25mm <sup>2</sup> - 300mm <sup>2</sup>
(b) Contact Termination	Screw or Crimp
Mating Method	Bayonet Lock
Operating Voltage	1000Vac
Max Rated Voltage to Earth	2KVac/3KVdc
Minimum Flashover	9.5KVdc or AC Peak
Insulation Resistance	>5M ohms @500Vdc
(d) Ingress Protection	IP68
Protection against electric shock	IP2X
Flammability	UL94-VO
Mating cycles	>500
Shell Material	High Temperature Thermoplastic
Contact Plating	Silver

### Powersafe Part Number Configurator / Ordering Codes for Complete Connectors

Type	Key Position	Colour	Contact Type	Cable Grip Clamping Range
<b>SLS</b>	<b>E</b>	<b>GN</b>	<b>S120</b>	<b>40A</b>
SLS = Line Source	E= Earth	GN = Green	S120 = 120mm <sup>2</sup> Set screw	40B = 22-32mm
SLD= Line Drain	N= Neutral	BL = Blue	C300 = 300mm <sup>2</sup> Crimp	40A= 19-28mm
SPS = Panel Source	1 = Line 1	BN = Brown	C240 = 240mm <sup>2</sup> crimp	40S = 15=23mm
SPD = Panel Drain	2 = Line 2	BK = Black	C185 = 185mm <sup>2</sup> crimp	
	3 = Line 3	GY = Grey	C150 = 150mm <sup>2</sup> crimp	
		R = Red	C120 = 120mm <sup>2</sup> crimp	
		Y = Yellow	C95 = 95mm <sup>2</sup> Crimp	
		W = White	C70 = 70mm <sup>2</sup> Crimp	
			C50 = 50mm <sup>2</sup> crimp	
			C35 = 35mm <sup>2</sup> Crimp	
			C25 = 25mm <sup>2</sup> Crimp	
			T5 = 500A threaded post	
			T8 = 800A threaded Post	

### International Electrical Colour Coding Standards

Region	Earth Key E	Neutral Key N	Phase 1 Key 1	Phase 2 Key 2	Phase 3 Key 3
Europe & UK (Harmonised) 	Green	Blue	Brown	Black	Grey
UK (Traditional) 	Green	Black	Red	Yellow	Blue
Australia 	Green	Black	Red		Blue
USA 	Green		Black	Red	Blue



## Powersafe Component Part and Accessory Ordering Code

Secondary Lock Release Key	SCP0095
R95 Reduction Sleeve for Screw terminal Contacts	PP00006
R70 Reduction Sleeve Kit for Screw terminal Contacts	PP00018
R50 Reduction Sleeve Kit for Screw terminal Contacts	PP00017
R35 Reduction Sleeve Kit for Screw terminal Contacts	PP00016
R25 Reduction Sleeve Kit for Screw terminal Contacts	PP00015
Protective Rubber Dustcap for Line Drain	SCP0096
Protective Rubber Dustcap for Line Source	SCP0097
Protective Rubber Dustcap for Panel Drain	SCP0098
Protective Rubber Dustcap for Panel Source	SCP0099
IP Environmental Locking Dustcap for Line Source*	SCP0100
IP Environmental Locking Dustcap for Line Drain*	SCP0101
IP Environmental Locking Dustcap for Panel Source*	SCP0102
IP Environmental Locking Dustcap for Panel Drain*	SCP0103
Rubber Hand Grip for Line Drain or Line Source	PP00050
Dowel Pin for Line Source	SCP0067
Panel Mounting Nut Plate for Panel Source and Panel Drain	PP00119
Dowel Pin for Line Drain	SCP0068
Dowel Pin for Panel Source or Panel Drain	SCP0004
Cable Gland for 22-32mm cable diameters (40B)	SCP0070
Cable Gland for 19-28mm cable diameters (40A)	SCP0069
Cable Gland for 15-23mm cable diameters (40S)	SCP0104
Insulator Kit Line Source Earth Green**	SCP0105
Insulator Kit Line Source Neutral Blue**	SCP0106
Insulator Kit Line Source Line 1 Brown**	SCP0107
Insulator Kit Line Source Line 2 Black**	SCP0108
Insulator Kit Line Source Line 3 Grey**	SCP0109
Insulator Kit Line Source Neutral Black**	SCP0115
Insulator Kit Line Source Line 1 Red**	SCP0116
Insulator Kit Line Source Line 2 Yellow**	SCP0117
Insulator Kit Line Source Line 2 White**	SCP0118
Insulator Kit Line Source Line 3 Blue**	SCP0119
Insulator Kit Line Drain Earth Green**	SCP0110
Insulator Kit Line Drain Neutral Blue**	SCP0111
Insulator Kit Line Drain Line 1 Brown**	SCP0112
Insulator Kit Line Drain Line 2 Black**	SCP0113
Insulator Kit Line Drain Line 3 Grey**	SCP0114
Insulator Kit Line Drain Neutral Black**	SCP0120
Insulator Kit Line Drain Line 1 Red**	SCP0121
Insulator Kit Line Drain Line 2 Yellow**	SCP0122
Insulator Kit Line Drain Line 2 White**	SCP0123
Insulator Kit Line Drain Line 3 Blue**	SCP0124
S120 Contact Kit for Line Source***	SCP0065
S120 Contact Kit for Line Drain***	SCP0066
C240 Contact for Line Source	SCP0071
C240 Contact for Line Drain	SCP0072

\* For IP Environmental Locking Dustcap, specify Key and Colour e.g.SCP0100-E-GN.

\*\* Insulator Kits consist of a complete marked and labeled insulator, with Dowel Pin.  
(Excludes cable gland and contact which can be ordered separately)

\*\*\* S120 Contact kit consists of complete contact assembly for 120mm sq cable section and includes R120 Sleeve.

## Dimensions and Panel Cut-out Details

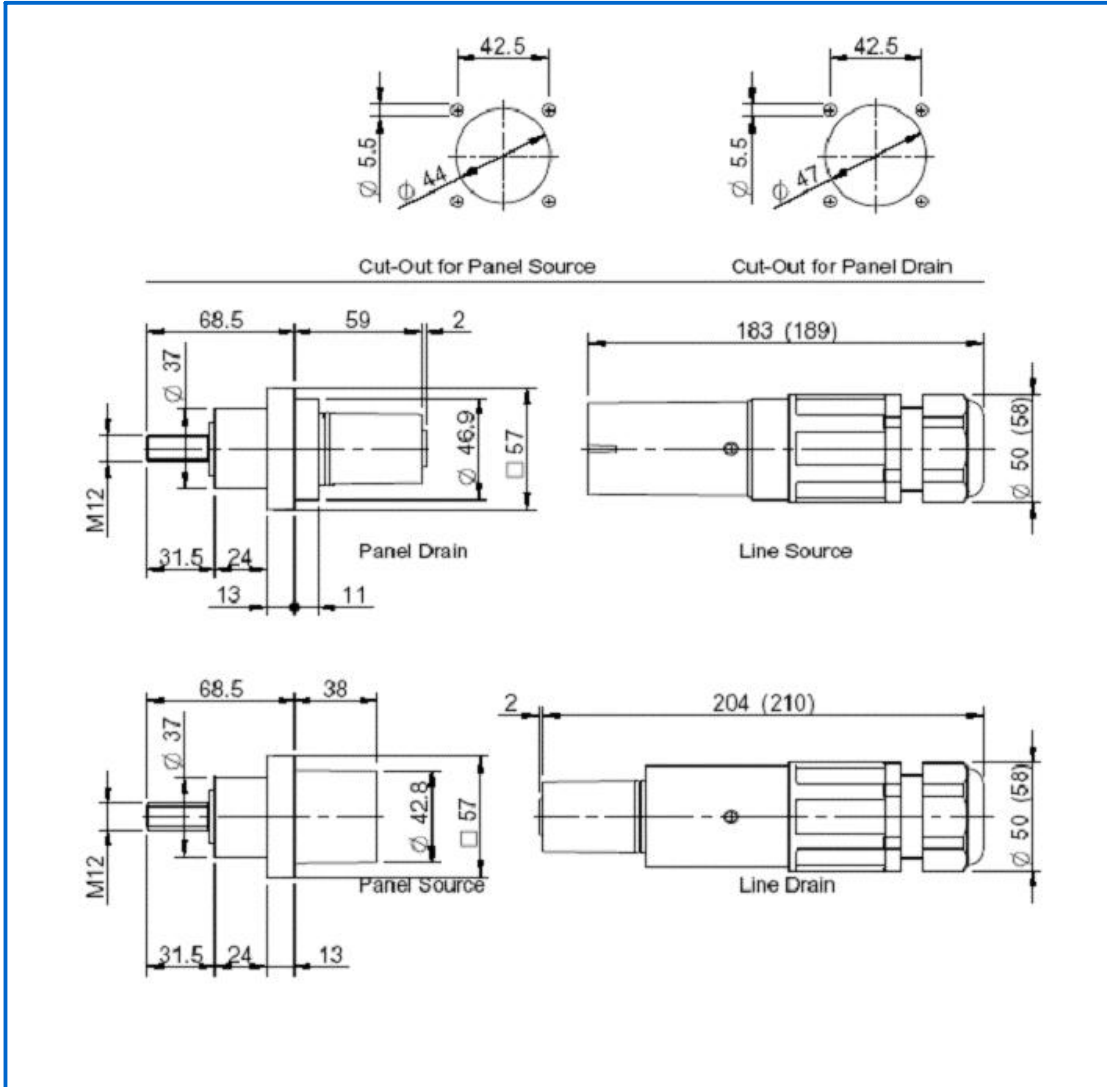

## Line Source Connector

- Line Source connector with finger proof contacts to prevent accidental touching of live elements.
- These connectors are supplied with an M40A or M40S cable gland for cables up to 19mm diameter or a larger M40B cable gland for cables up to 32mm diameter.
- The connectors are supplied colour coded and mechanically keyed to prevent connection errors.
- The Line source will mate with a Line Drain or Panel Mounted Drain connector.
- Available in crimp version for cables up to 300mm sq and set screw version for cables up to 150mm sq cable sections.

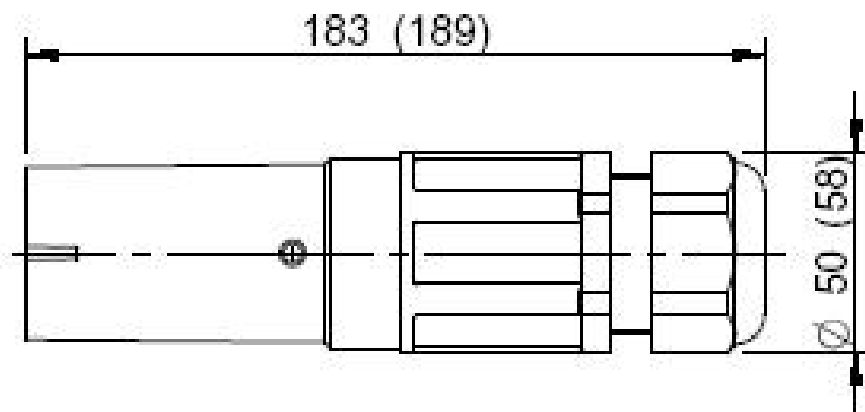

Line Source

## Line Drain Connector

- Line Drain connector with finger proof contacts to prevent accidental touching of live elements. *A non finger proof version is also available.*
- These connectors are supplied with an M40A or M40S cable gland for cables up to 19mm diameter or a larger M40B cable gland for cables up to 32mm diameter.
- The connectors are supplied colour coded and mechanically keyed to prevent connection errors.
- A secondary spring loaded pin is fitted to the connector which will engage with a slot in the Source connector version to prevent accidental disconnection under load.
- The line Drain will mate with a Line Source or Panel Mounted Source connector.
- Available in crimp version for cables up to 300mm sq and set screw version for cables up to 150mm sq cable sections.

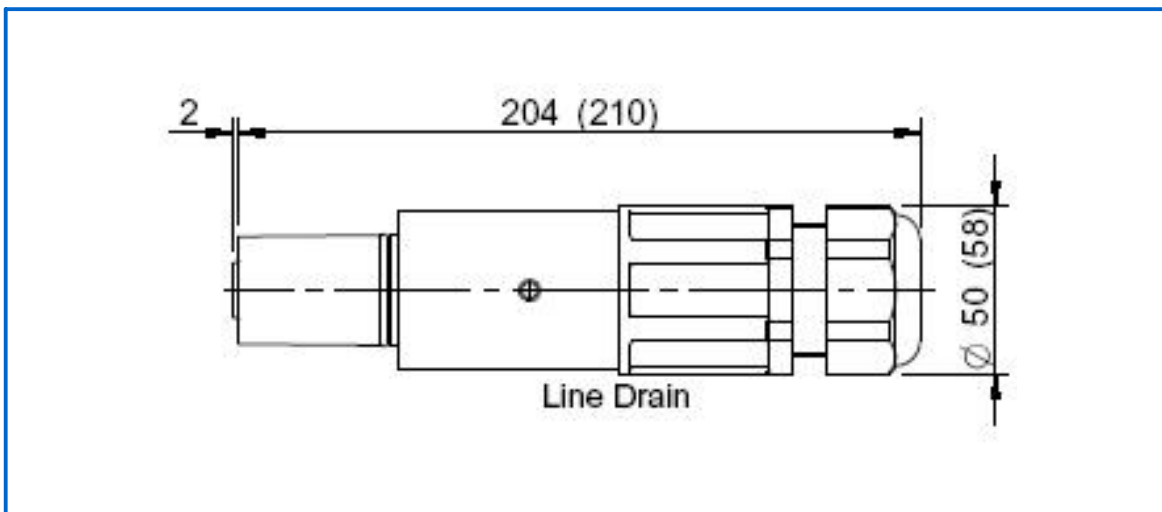

## Panel Source Connector

- Panel Source connector with finger proof contacts to prevent accidental touching of live elements.
- These connectors are supplied with M12 threaded post termination as standard, to accept cable lugs.
- Nut plates available for ease of mounting on equipment panels
- Crimp versions available. See ordering code page.
- The connectors are supplied Colour coded and mechanically keyed to prevent connection errors.
- The Panel source will mate with a Line Drain connector.
- 500A and 800A versions available
- *Camlok mountable versions available on request.*

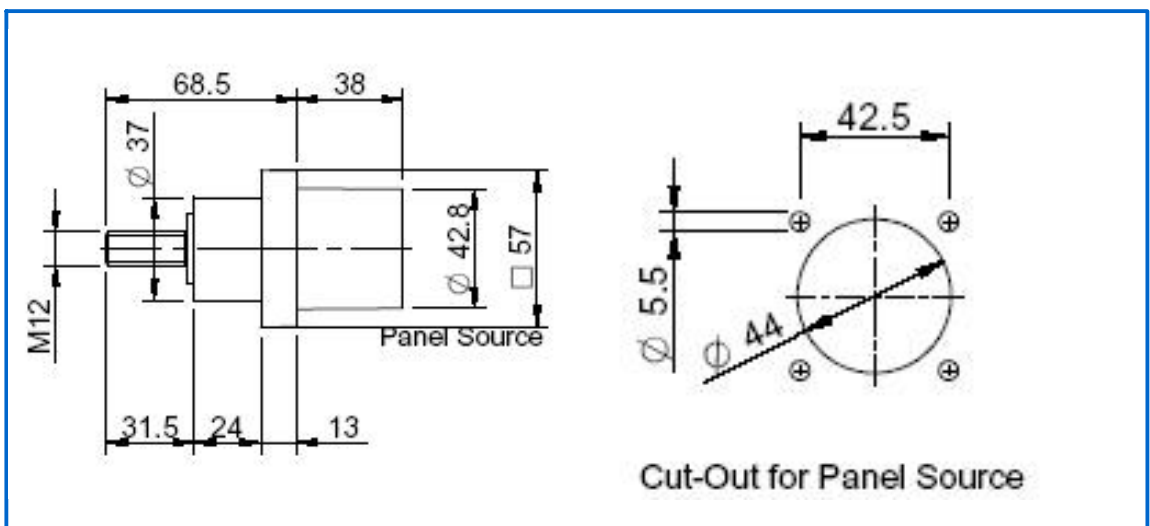

## Panel Drain Connector

- Panel Drain connector with finger proof contacts to prevent accidental touching of live elements.
- These connectors are supplied with M12 threaded post termination as standard, to accept cable lugs.
- Nut plates available for ease of mounting on equipment panels
- A secondary spring loaded pin is fitted to the connector which will engage with a slot in the Source connector version to prevent accidental disconnection under load.
- Crimp versions available. See ordering code page.
- The connectors are supplied Colour coded and mechanically keyed to prevent connection errors.
- The Panel Drain will mate with a Line Source connector
- 500A and 800A versions available
- *Camlok mountable versions available on request.*

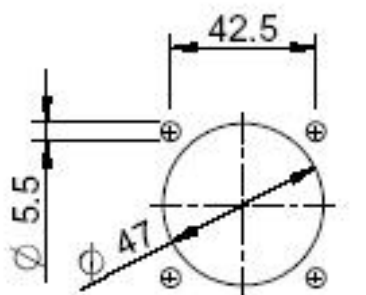

Cut-Out for Panel Drain

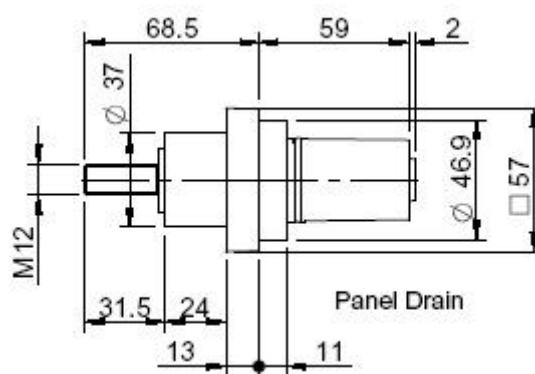

Panel Drain

## Accessories

### Protective Caps

Protective caps help to protect your investment and extend the life span of the connectors. Two versions are available.

#### Push pull caps offer basic protection.

The caps are manufactured in rubber, which help to

- Prevent abrasion and impact damage to the mating faces of the connectors.
- Prevent the entry of dirt and water into the contact area when the connectors are unmated.

#### Environmental caps offer increased protection.

These caps are manufactured in high impact Thermoplastic. In addition to the features of the push pull cap system, they offer

- IP rated sealing
- Locking feature to prevent the cap being removed with use of the secondary locking key.
- Colour Coding

### Nut Plates

Nut plates are a cost effective solution to reduce your equipment assembly time. These plates are manufactured in steel and power coated. The plate carries four threaded steel inserts, which effectively eliminate the need for washers and nuts, and is supplied with four nylon screws (other material on request). This makes mounting of the panel connector to equipment panel extremely easy and fast. The connector is simply pushed into the panel cut out, then the plate fitted behind the panel. The four screws are then fitted. So no spanners or wrenches required! The same plate fits both Source and Drain connectors.

### Rubber Hand Grips

Ergonomic Rubber Hand Grips can be fitted to the Line connectors. This provides increased impact protection, and allows for easy coupling and uncoupling of the connectors, in all weather environments

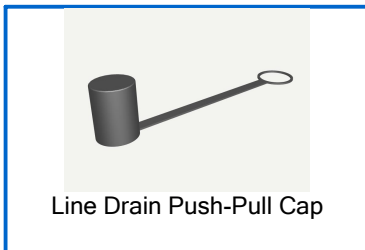
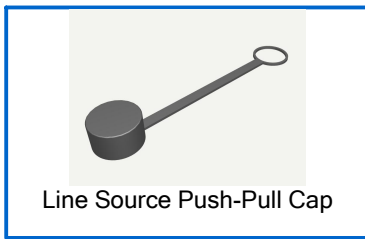

## Special Products

Our extensive in house engineering and manufacturing capabilities, allow us to quickly respond to customer requirements for new products and modifications to existing products to facilitate specific application requirements.

## Related Products

In addition to the Powersafe connector series we also offer a diverse range of related products, which are specifically designed for particular market applications. These include

- Electricity Network Clamps and Connectors
- Sequential Mating Input and Output panels.
- Cable Lug to Lug Connection Units
- Power Distribution Boxes and Systems
- Cable Splitters
- Power cables
- Cable assemblies
- Cable deployment systems

For further details please call our sales office.

## Further Information

Specific product catalogues for the extended range of products are available from our sales office on request.

## Assembly and Tooling

The Powersafe connector series is a high performance high quality product when correctly assembled Powersafe will deliver long term safe and reliable performance,. A termination procedure detailing the correct method for terminating cables to the connector is available on request. This details the correct crimp tools and dies, cable preparation and final assembly techniques. *Phase 3 UK warrant the connectors' performance only when correctly assembled in accordance with this procedure.*



**PHASE3**  
Our extended range of products also include:

- 1. Safety
- 2. Earth Clamps
- 3. Insulated Clamps
- 4. Cable Lugs
- 5. Cable Splitters
- 6. Mechanical Connectors
- 7. Power and Voltage Boxes
- 8. Power Distribution Boxes
- 9. Connectors

**Planned power outages can now be a thing of the past.**

Our extended range of products also include:

PHASE3 UK  
Tel: +44 (0)1202 770000  
Fax: +44 (0)1202 770001  
Email: sales@phase3.com  
www.phase3.com











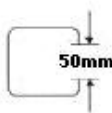

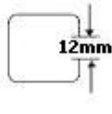
**EZ series FLEXIBLE RUBBER POWER**

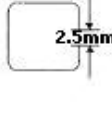
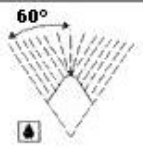
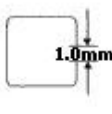
**CONNECT WITH PHASE 3**

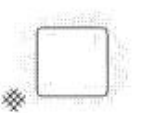
For this EZ Series, you can now get the best Network Connection Direct from manufacture.

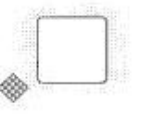
PHASE3 UK  
Tel: +44 (0)1202 770000  
Fax: +44 (0)1202 770001  
Email: sales@phase3.com  
www.phase3.com

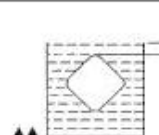
## Appendix 1

IP54 = IP Letter Code _____ IP			
1st Digit _____ 5		2nd Digit _____ 4	
1st Digit	Protection from solid objects	2nd Digit	Protection from moisture
0	Non protected	0	Non protected
1	 Protected against solid objects greater than 50mm	1	 Protected against dripping water
2	 Protected against solid objects greater than 12mm	2	 Protected against dripping water when tilted up to 15°
3	 Protected against solid objects greater than 2.5mmØ	3	 Protected against spraying water
4	 Protected against solid objects greater than 1.0mmØ	4	 Protected against splashing water
5	 Dust protected	5	 Protected against water jets
6	 Dust tight	6	 Protected against heavy seas
<b>Note: EN 60529 does not specify sealing effectiveness against the following: mechanical damage of the equipment; the risk of explosions; certain types of moisture conditions, e.g. those that are produced by condensation; corrosive vapours; fungus; vermin</b>		7	 Protected against the effects of immersion
		8	 Protected against submersion (see note)

**IP68 note:** Submersion depth and time must be specified by the end-user. The requirement must be more onerous than IP67

## Index

### Page

3	Introduction
4	Product Features
5	Electrical Performance
6	Band Technology
7	Band Design
8	Cable Ratings
9	Connector Technical Overview
10	Connector Ordering Codes
11	Accessory Ordering Codes
12	Dimensional Data
13	Line Source Connector Overview
14	Line Drain Connector Overview
15	Panel Source Connector Overview
16	Panel Drain Connector Overview
17	Accessories
18	Related Products and Further Information
19	IP Rating chart (Appendix 1)